

WIRING PARKING LIGHTS ON 2008-Up Ford Super Duty Pickups



NOTE:

2008-up Ford Super Duty Pickups DO NOT use a (+) parking light wire.

- ▶ To properly trigger the parking lights you must ground the GRAY and interrupt the WHITE/VIOLET wire at the light switch, or if the vehicle has auto headlights, you must ground the GRAY wire, and interrupt the WHITE VIOLET **AND** VIOLET/GREEN. This must be done to avoid feedback to the headlights.

i NOTE: For models without auto headlights, wire as shown:

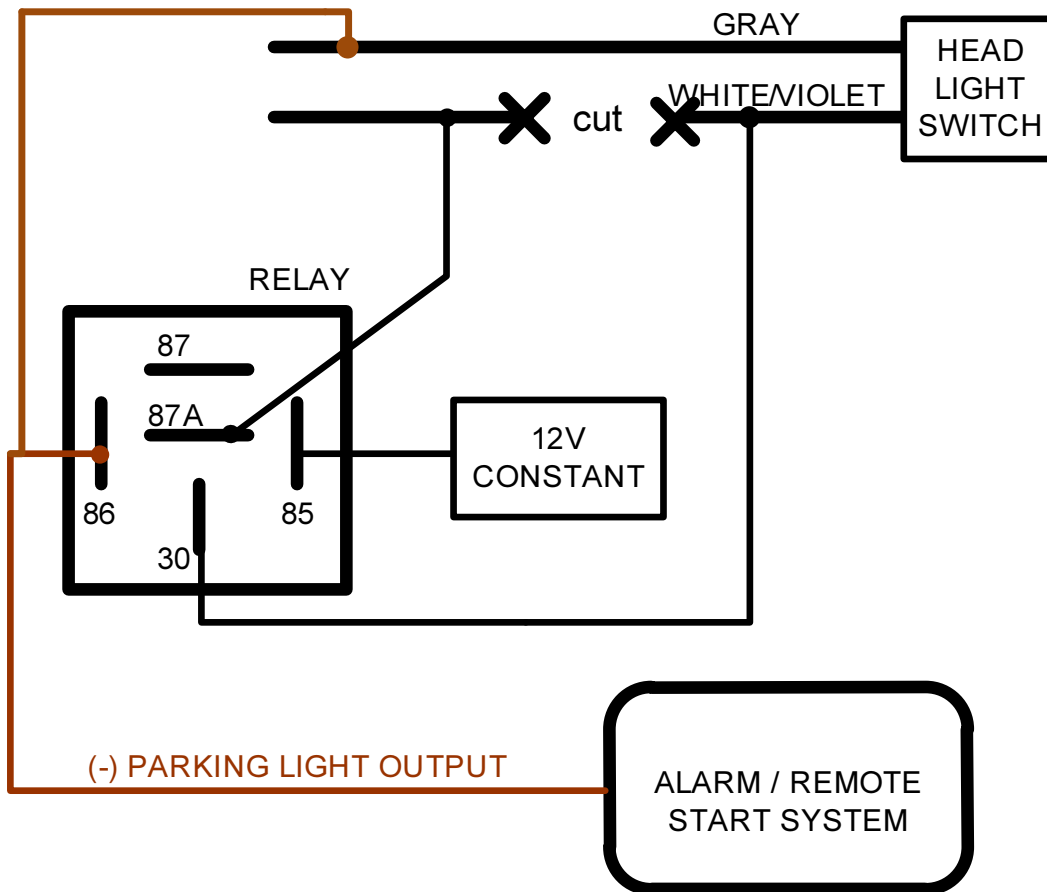

PIN	CONNECTION
85	TO 12V CONSTANT FUSED
86	(-) PARKING LIGHT OUTPUT AND TO GRAY WIRE
87	NO CONNECTION
87A	TO WHITE/VIOLET WIRE AT HEADLIGHT SWITCH – LIGHT SIDE
30	TO WHITE/VIOLET WIRE AT HEADLIGHT SWITCH – HEADLIGHT SWITCH SIDE

Remote starter and security installations should be attempted by experienced security installers only. Information contained is accurate to the best of our knowledge and experience. Information contained is without any representation of warranty. It is the installer's responsibility to test and confirm all circuits with a digital multi-meter. Proper installation remains the responsibility of the installer. CarInstallExperts.com assumes no liability or responsibility resulting from an improper installation, even in reliance with the information contained in this guide.

NOTE: For 2008 Ford Super Duty Pickups with auto headlights, wire as shown below:

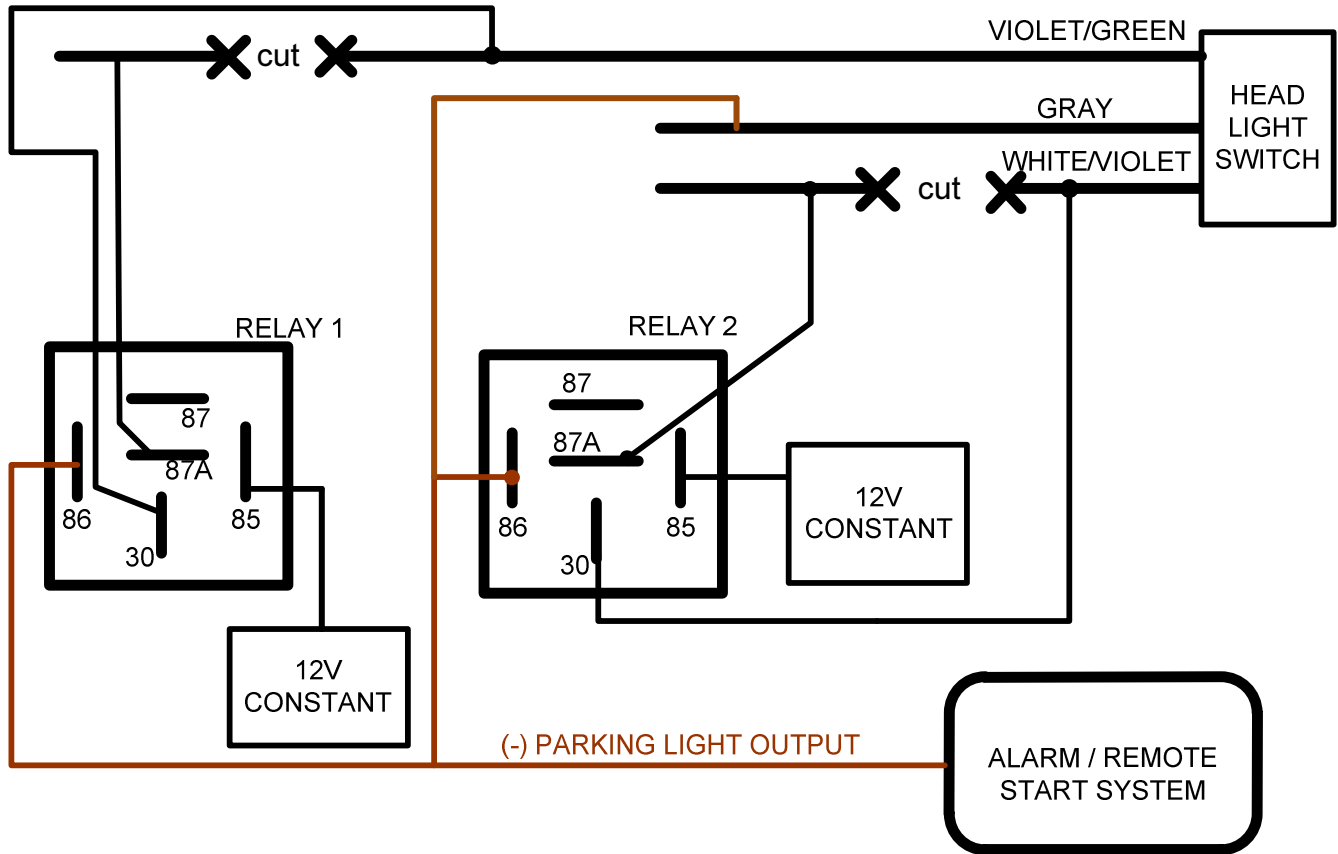

RELAY 1

PIN	CONNECTION
85	TO CHASSIS GROUND
86	TO (+) PARKING LIGHT OUTPUT FROM ALARM/REMOTE START SYSTEM
87	TO PIN 87 OF RELAY 2
87A	TO DK.BLUE/WHITE WIRE – CAR SIDE
30	TO DK.BLUE/WHITE WIRE – HEADLIGHT SWITCH SIDE

RELAY 2

PIN	CONNECTION
85	TO CHASSIS GROUND
86	TO (+) PARKING LIGHT OUTPUT FROM ALARM/REMOTE START SYSTEM
87	TO BLACK/LT.GREEN WIRE AT HEADLIGHT SWITCH
87A	TO TAN/WHITE WIRE AT HEADLIGHT SWITCH – CAR SIDE
30	TO TAN/WHITE WIRE AT HEADLIGHT SWITCH – HEADLIGHT SWITCH SIDE

Remote starter and security installations should be attempted by experienced security installers only. Information contained is accurate to the best of our knowledge and experience. Information contained is without any representation of warranty. It is the installer's responsibility to test and confirm all circuits with a digital multi-meter. Proper installation remains the responsibility of the installer. CarInstallExperts.com assumes no liability or responsibility resulting from an improper installation, even in reliance with the information contained in this guide.